

Product Specification

CONTENTS

NO.	ITEM	Page
-	COVER	1
-	CONTENTS	2
-	RECORD OF REVISIONS	3
1	GENERAL DESCRIPTION	4
2	ABSOLUTE MAXIMUM RATINGS	5
3	ELECTRICAL SPECIFICATIONS	6
3-1	ELECTRICAL CHARACTERISTICS	6
3-2	INTERFACE CONNECTIONS	8
3-3	SIGNAL TIMING SPECIFICATIONS	11
3-4	SIGNAL TIMING WAVE FORMS	12
3-5	COLOR INPUT DATA REFERANCE	13
3-6	POWER SEQUENCE	14
4	OPTICAL SPECIFICATIONS	15
5	MECHANICAL CHARACTERISTICS	19
6	RELIABILITY	22
7	INTERNATIONAL STANDARDS	23
7-1	SAFETY	23
7-2	EMC	23
8	PACKING	24
8-1	DESIGNATION OF LOT MARK	24
8-2	PACKING FORM	24
9	PRECAUTIONS	25

Product Specification

1. General Description

The LM181ES-A3 is a Color Active Matrix Liquid Crystal Display with an integral Cold Cathode Fluorescent Lamp(CCFL) backlight system. The matrix employs a-Si Thin Film Transistor as the active element. It is a transmissive type display operating in the normally black mode. This TFT-LCD has a 18.1 inch diagonally measured active display area with SXGA resolution(1024 vertical by 1280 horizontal pixel array). Each pixel is divided into Red, Green and Blue sub-pixels or dots which are arranged in vertical stripes. Gray scale or the brightness of the sub-pixel color is determined with a 8-bit gray scale signal for each dot, thus, presenting a palette of more than 16,777,216 colors.

The LM181ES-A3 has been designed to apply the interface method that enables low power, high speed, low EMI. FPD Link must be used as a LVDS(Low Voltage Differential Signaling) chip. The LM181ES-A3 is intended to support applications where thin thickness, wide viewing angle, low power are critical factors and graphic displays are important. In combination with the vertical arrangement of the sub-pixels, the LM181ES-A3 characteristics provide an excellent flat panel display for office automation products such as monitors.

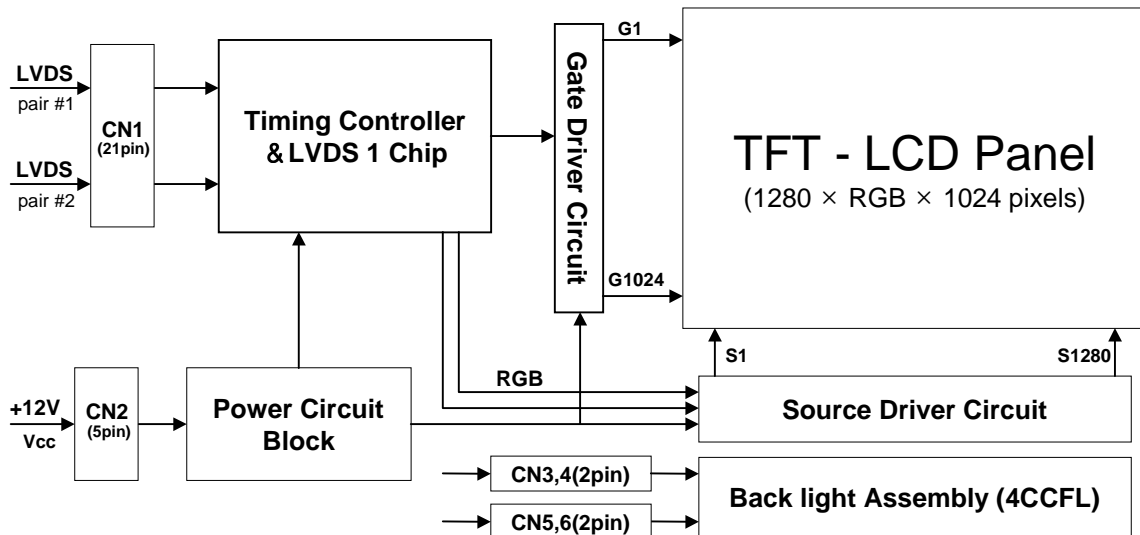

General Features

Active screen size	18.1 inches (45.974cm) diagonal
Outline Dimension	412.5(H) x 333.0(V) x 22.5(D) mm(Typ.)
Pixel Pitch	0.2805 mm x 0.2805 mm
Pixel Format	1280 horizontal By 1024 vertical Pixels RGB stripe arrangement
Color depth	8-bits, 16,777,216 colors
Luminance, white	200 cd/m ² (Typ.)
Power Consumption	Total 27.96 Watt(Typ.), (5.4Watt @Vcc, 22.56 Watts @200cd/m ² [Lamp])
Weight	2835g (Max.)
Display operating mode	Transmissive mode, normally black
Surface treatments	Hard coating (3H), Anti-glare treatment of the front polarizer

Product Specification

3. Electrical Specifications

3-1. Electrical Characteristics

The LM181ES-A3 requires two power inputs. One is employed to power the LCD electronics and to drive the TFT array and liquid crystal. The second input which powers the CCFL, is typically generated by an inverter. The inverter is an external unit to the LCD.

Table 2. ELECTRICAL CHARACTERISTICS

Parameter	Symbol	Values			Units	Notes
		Min.	Typ.	Max.		
MODULE :						
Power Supply Input Voltage	V _{CC}	11.2	12.0	12.6	V(DC)	
Power Supply Input Current	I _{CC}	–	0.42	0.76	A	1
Differential Impedance	Z _m	90	100	110	Ohm	2
Power Consumption	P _C	–	5.4	9.1	Watts	1
Rush Current	I _{RUSH}	–	0.7	1.0	A	3
LAMP :						
Operating Voltage	V _{BL}	700(8.3)	705(8.0)	855(3.0)	V _{RMS}	4
Operating Current	I _{BL}	3.0	8.0	8.3	mA _{RMS}	
Established Starting Voltage	V _S					5
at 25°C	–	–	–	1080	V _{RMS}	
at 0°C	–	–	–	1500	V _{RMS}	
Operating Frequency	F _{BL}	30	50	80	KHz	6
Discharge Stabilization Time	T _S	–	–	3	Minutes	7
Power Consumption(4CCFL's)	P _{BL}	–	22.56	24.84	Watts	8
Life Time	–	20,000	30,000	–	Hrs	9

Note : The design of the inverter must have specifications for the lamp in LCD Assembly.

The performance of the Lamp in LCM, for example life time or brightness, is extremely influenced by the characteristics of the DC-AC inverter. So all the parameters of an inverter should be carefully designed so as not to produce too much leakage current from high-voltage output of the inverter.

When you design or order the inverter, please make sure unwanted lighting caused by the mismatch of the lamp and the inverter(no lighting, flicker, etc) never occurs. When you confirm it, the LCD Assembly should be operated in the same condition as installed in you instrument.

1. The specified current and power consumption are under the V_{CC}=12.0V, 25°C, f_v=60Hz condition, Typical supply current is measured at the condition of 8 X 6 chess pattern(white & black)
2. This impedance value is for impedance matching between LVDS T_x and the mating connector of the LCD.
3. The duration of rush current is about 20ms.
4. The variance of the voltage is ± 10%.
5. The voltage above V_S should be applied to the lamps for more than 1 second for start-up. Otherwise, the lamps may not be turned on.

Product Specification

6. The output of the inverter must have symmetrical (negative and positive) voltage waveform and symmetrical current waveform. (Unsymmetrical ratio is less than 10%) Please do not use the inverter which has unsymmetrical voltage and unsymmetrical current and spike wave.
Lamp frequency may produce interference with horizontal synchronous frequency and as a result this may cause beat on the display. Therefore lamp frequency shall be as away possible from the horizontal synchronous frequency and from its harmonics in order to prevent interference.
 7. Let's define the brightness of the lamp after being lighted for 5 minutes as 100%.
 T_S is the time required for the brightness of the center of the lamp to be not less than 95%.
The used lamp current is lamp typical current.
 8. The lamp power consumption shown above does not include loss of external inverter.
The used lamp current is the lamp typical current.
 9. The life time is determined as the time at which brightness of the lamp is 50% compared to that of initial value at the typical lamp current on condition of continuous operating at $25 \pm 2^\circ\text{C}$.
Typical life time shall be defined that remained rate maintains over 50% of total amount at the life test.
- ◆ Do not attach a conductive tape to lamp connecting wire.
If the lamp wire attach to a conducting tape, TFT-LCD Module has a low luminance and the inverter has abnormal action. Because leakage current is occurred between lamp wire and conducting tape.

Product Specification

3-2. Interface Connections

Interface chip must be used LVDS, part No. DS90CF383MTD(Transmitter), DS90CF384MTD(Receiver) made by Nation Semiconductor. Or used the compatible interface chips(TI:SN75LVDS83, Thine). This LCD employs six interface connections, a 21-pin connector is used for the module electronics interface. A 5-pin connector is used for the module power(+12V) . Four 2-pin connectors are used for the integral back-light system. The electronics interface connector is a model GT121-21P-TD manufactured by LGC. The pin configuration for the connector is shown in the table 3.

Table 3. MODULE CONNECTOR PIN CONFIGURATION(LVDS)

Pin	Symbol	Description	
1	FR3P	Plus signal of odd channel 3 (LVDS)	First data
2	FR3M	Minus signal of odd channel 3 (LVDS)	
3	FCLKINP	Plus signal of odd clock channel (LVDS)	
4	FCLKINM	Minus signal of odd clock channel (LVDS)	
5	FR2P	Plus signal of odd channel 2 (LVDS)	
6	FR2M	Minus signal of odd channel 2 (LVDS)	
7	FR1P	Plus signal of odd channel 1 (LVDS)	
8	FR1M	Minus signal of odd channel 1 (LVDS)	
9	FR0P	Plus signal of odd channel 0 (LVDS)	
10	FR0M	Minus signal of odd channel 0 (LVDS)	
11	SR3P	Plus signal of even channel 3 (LVDS)	Second data
12	SR3M	Minus signal of even channel 3 (LVDS)	
13	SCLKINP	Plus signal of even clock channel (LVDS)	
14	SCLKINM	Minus signal of even clock channel (LVDS)	
15	SR2P	Plus signal of even channel 2 (LVDS)	
16	SR2M	Minus signal of even channel 2 (LVDS)	
17	SR1P	Plus signal of even channel 1 (LVDS)	
18	SR1M	Minus signal of even channel 1 (LVDS)	
19	SR0P	Plus signal of even channel 0 (LVDS)	
20	SR0M	Minus signal of even channel 0 (LVDS)	
21	NC	Not connected	

The backlight interface connector is a model BHSR-02VS-1, manufactured by JST. The mating connector part number is SM02B-BHS-1 or equivalent. The pin configuration for the connector is shown in the table 4.

Table 4. BACKLIGHT CONNECTOR PIN CONFIGURATION

Pin	Symbol	Description	Notes
1	HV	Power supply for lamp (High voltage side)	1
2	LV	Power supply for lamp (Low voltage side)	1

Note : 1. The high voltage side terminal is colored pink & white. The low voltage side terminal is yellow & white

Product Specification
Table 6. REQUIRED SIGNAL ASSIGNMENT FOR FlatLink Transmitter

Pin #	Pin Name	Require Signal	Pin #	Pin Name	Require Signal
1	VCC	Power Supply for TTL Input	29	GND	Ground pin for TTL
2	D5	TTL Input (R7)	30	D26	TTL Input (R7)
3	D6	TTL Input (R5)	31	T _x CLKIN	TTL Level clock Input
4	D7	TTL Input (G0)	32	PWR DWN	Power Down Input
5	GND	Ground pin for TTL	33	PLL GND	Ground pin for PLL
6	D8	TTL Input (G1)	34	PLL VCC	Power Supply for PLL
7	D9	TTL Input (G2)	35	PLL GND	Ground pin for PLL
8	D10	TTL Input (G6)	36	LVDS GND	Ground pin for LVDS
9	VCC	Power Supply for TTL Input	37	T _x OUT3+	Positive LVDS differential data output 3
10	D11	TTL Input (G7)	38	T _x OUT3-	Negative LVDS differential data output 3
11	D12	TTL Input (G3)	39	T _x CLKOUT+	Positive LVDS differential clock output
12	D13	TTL Input (G4)	40	T _x CLKOUT-	Negative LVDS differential clock output
13	GND	Ground pin for TTL	41	T _x OUT2+	Positive LVDS differential data output 2
14	D14	TTL Input (G5)	42	T _x OUT2-	Negative LVDS differential data output 2
15	D15	TTL Input (B0)	43	LVDS GND	Ground pin for LVDS
16	D16	TTL Input (B6)	44	LVDS VCC	Power Supply for LVDS
17	VCC	Power Supply for TTL Input	45	T _x OUT1+	Positive LVDS differential data output 1
18	D17	TTL Input (B8)	46	T _x OUT1-	Negative LVDS differential data output 1
19	D18	TTL Input (B1)	47	T _x OUT0+	Positive LVDS differential data output 0
20	D19	TTL Input (B2)	48	T _x OUT0-	Negative LVDS differential data output 0
21	GND	Ground pin for TTL Input	49	LVDS GND	Ground pin for TTL
22	D20	TTL Input (B3)	50	D27	TTL Input (R6)
23	D21	TTL Input (B4)	51	D0	TTL Input (R0)
24	D22	TTL Input (B5)	52	D1	TTL Input (R1)
25	D23	TTL Input (RSVD)	53	GND	Ground pin for TTL
26	VCC	Power Supply for TTL Input	54	D2	TTL Input (R2)
27	D24	TTL Input (HSYNC)	55	D3	TTL Input (R3)
28	D25	TTL Input (VSYNC)	56	D4	TTL Input (R4)

Notes : Refer to LVDS Transmitter Data Sheet for detail descriptions.

Product Specification

3-3. Signal Timing Specifications

This is the signal timing required at the input of the LVDS Transmitter. All of the interface signal timing should be satisfied with the following specifications for it's proper operation.

Table 7. TIMING TABLE

	ITEM	SYMBOL	MIN	TYP	MAX	UNIT	NOTES
Dclk	Period	t_{CLK}	18.52	18.52	18.52	ns	
	Frequency	–	54	54	54	MHz	
Hsync	Period	t_{HP}	760	844	928	t_{CLK}	
	Width	t_{WH}	8	56	240		
Vsync	Period	t_{VP}	1032	1066	1097	t_{HP}	
	Frequency	f_V	60	60	60	Hz	
	Width	t_{WV}	2	3	24	t_{HP}	
DE (Data Enable)	Horizontal Valid	t_{HV}	640	640	640	t_{CLK}	
	Horizontal Back Porch	t_{HBP}	12	124	–		
	Horizontal Front Porch	t_{HFP}	8	24	–		
	Horizontal Blank	–	120	–	$t_{HP} - t_{HV}$		
	Vertical Valid	t_{VV}	1024	1024	1024	t_{HP}	
	Vertical Back Porch	t_{VBP}	1	38	–		
	Vertical Front Porch	t_{VFP}	1	1	1		
	Vertical Blank	–	8	–	$t_{VP} - t_{VV}$		

Product Specification

3-5. Color Input Data Reference

The brightness of each primary color(red,green and blue) is based on the 8-bit gray scale data input for the color ; the higher the binary input, the brighter the color. The table below provides a reference for color versus data input.

Table 8. COLOR DATA REFERENCE

Color		Input Color Data																							
		Red								Green								Blue							
		MSB				LSB				MSB				LSB				MSB				LSB			
		R7	R6	R5	R4	R3	R2	R1	R0	G7	G6	G5	G4	G3	G2	G1	G0	B7	B6	B5	B4	B3	B2	B1	B0
Basic Colors	Black	0	0	0	0	0	0	0	0	0	0	0	0	0	0	0	0	0	0	0	0	0	0	0	
	Red(255)	1	1	1	1	1	1	1	1	0	0	0	0	0	0	0	0	0	0	0	0	0	0	0	
	Green(255)	0	0	0	0	0	0	0	0	1	1	1	1	1	1	1	0	0	0	0	0	0	0	0	
	Blue(255)	0	0	0	0	0	0	0	0	0	0	0	0	0	0	0	1	1	1	1	1	1	1	1	
	Cyan	0	0	0	0	0	0	0	0	1	1	1	1	1	1	1	1	1	1	1	1	1	1	1	
	Magenta	1	1	1	1	1	1	1	1	0	0	0	0	0	0	0	0	1	1	1	1	1	1	1	
	Yellow	1	1	1	1	1	1	1	1	1	1	1	1	1	1	1	0	0	0	0	0	0	0	0	
	White	1	1	1	1	1	1	1	1	1	1	1	1	1	1	1	1	1	1	1	1	1	1	1	
Red	Red(000) Dark	0	0	0	0	0	0	0	0	0	0	0	0	0	0	0	0	0	0	0	0	0	0		
	Red(001)	0	0	0	0	0	0	0	1	0	0	0	0	0	0	0	0	0	0	0	0	0	0		
	Red(002)	0	0	0	0	0	0	1	0	0	0	0	0	0	0	0	0	0	0	0	0	0	0		
	: : : : :	:	:	:	:	:	:	:	:	:	:	:	:	:	:	:	:	:	:	:	:	:	:		
	Red(253)	1	1	1	1	1	1	0	1	0	0	0	0	0	0	0	0	0	0	0	0	0	0		
	Red(254)	1	1	1	1	1	1	1	0	0	0	0	0	0	0	0	0	0	0	0	0	0	0		
	Red(255) Bright	1	1	1	1	1	1	1	1	0	0	0	0	0	0	0	0	0	0	0	0	0	0		
Green	Green(000) Dark	0	0	0	0	0	0	0	0	0	0	0	0	0	0	0	0	0	0	0	0	0	0		
	Green(001)	0	0	0	0	0	0	0	0	0	0	0	0	0	0	1	0	0	0	0	0	0	0		
	Green(002)	0	0	0	0	0	0	0	0	0	0	0	0	0	1	0	0	0	0	0	0	0	0		
	: : : : :	:	:	:	:	:	:	:	:	:	:	:	:	:	:	:	:	:	:	:	:	:	:		
	Green(253)	0	0	0	0	0	0	0	0	1	1	1	1	1	1	0	1	0	0	0	0	0	0		
	Green(254)	0	0	0	0	0	0	0	0	1	1	1	1	1	1	1	0	0	0	0	0	0	0		
	Green(254) Bright	0	0	0	0	0	0	0	0	1	1	1	1	1	1	1	0	0	0	0	0	0	0		
Blue	Blue(000) Dark	0	0	0	0	0	0	0	0	0	0	0	0	0	0	0	0	0	0	0	0	0	0		
	Blue(001)	0	0	0	0	0	0	0	0	0	0	0	0	0	0	0	0	0	0	0	0	0	1		
	Blue(002)	0	0	0	0	0	0	0	0	0	0	0	0	0	0	0	0	0	0	0	0	0	1		
	: : : : :	:	:	:	:	:	:	:	:	:	:	:	:	:	:	:	:	:	:	:	:	:	:		
	Blue(253)	0	0	0	0	0	0	0	0	0	0	0	0	0	0	0	1	1	1	1	1	1	0		
	Blue(254)	0	0	0	0	0	0	0	0	0	0	0	0	0	0	0	1	1	1	1	1	1	0		
	Blue(255) Bright	0	0	0	0	0	0	0	0	0	0	0	0	0	0	0	1	1	1	1	1	1	1		

Product Specification

Notes : 1. Contrast Ratio(CR) is defined mathematically as :

$$\text{Contrast Ratio} = \frac{\text{Surface Luminance with all white pixels}}{\text{Surface Luminance with all black pixels}}$$

2. Surface luminance is the center point across the LCD surface 50cm from the surface with all pixels displaying white under the condition of $L_{BL} = 8mArms$. For more information see FIG 2.
3. The variation in surface luminance , δ_{WHITE} is determined by measuring L_{ON} at each test position 1 through 5, and then dividing the maximum L_{ON} of 5 points luminance by minimum L_{ON} of 5 points luminance. For more information see FIG 2.
$$\delta_{WHITE} = \text{Maximum}(L_{ON1}, L_{ON2}, \dots, L_{ON5}) \div \text{Minimum}(L_{ON1}, L_{ON2}, \dots, L_{ON5})$$
4. Response time is the time required for the display to transition from black to white(Rise Time, Tr_R) and from white to black(Decay Time, Tr_D). For additional information see FIG 3.
5. Viewing angle is the angle at which the contrast ratio is greater than 10. The angles are determined for the horizontal or x axis and the vertical or y axis with respect to the z axis which is normal to the LCD surface. For more information see FIG 4.

Product Specification

FIG. 4 Viewing angle

<Definition of viewing angle range>

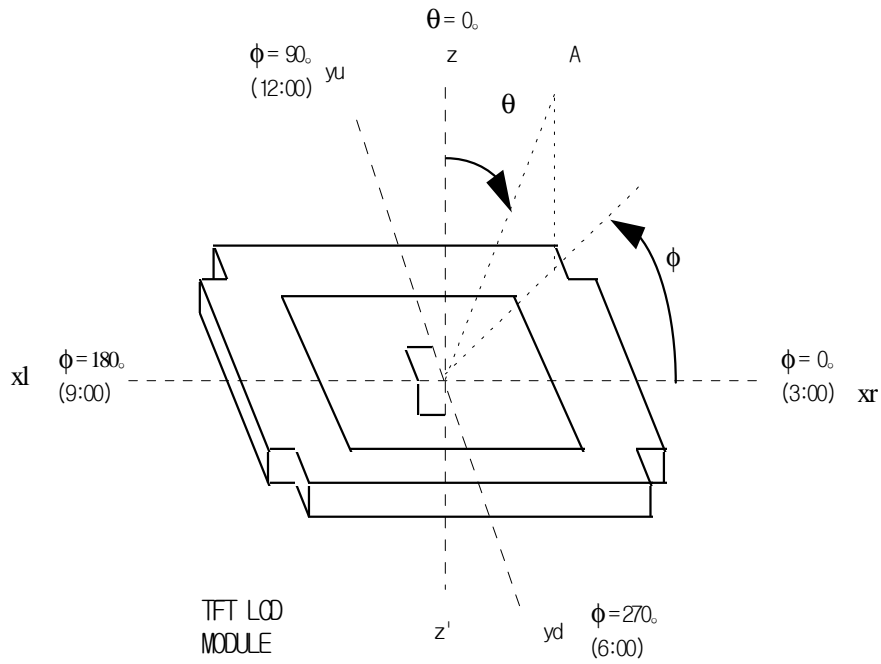

Product Specification

5. Mechanical Characteristics

The contents provide general mechanical characteristics for the model LM181ES-A3. In addition, the figures in the next page are detailed mechanical drawing of the LCD.

Outside dimensions	Horizontal	412.5 ± 0.5 mm
	Vertical	333.0 ± 0.5 mm
	Depth	22.5 ± 0.5 mm
Bezel area	Horizontal	363.5 ± 0.5 mm
	Vertical	292.0 ± 0.5 mm
Active display area	Horizontal	359.040 mm
	Vertical	287.232 mm
Weight (approximate)	2700g (Typ.), 2835g (Max.)	
Surface Treatment	Hard coating (3H) Anti-glare treatment of the front polarizer Haze (25%)	

Product Specification

6. Reliability

Environment test condition

No.	Test Item	Conditions
1	High temperature storage test	Ta= 60°C 240hr
2	Low temperature storage test	Ta= -20°C 240hr
3	High temperature operation test	Ta= 50°C 50%RH 240hr
4	Low temperature operation test	Ta= 0°C 240hr
5	Vibration test (non-operating)	1. Sinusoidal Vibration 1.0G zero to peak. 10 to 500 Hz, 0.5 oct/min sweep rate. 10 to 500, 10Hz, one Sweep along each axis. 2. Random Vibration 0.002 G ² /Hz, 10 to 500Hz, nominal 1 GRMS. One Hour for each of the three axis.
6	Shock test (non-operating)	1. Half sine wave shock: 120G peak, half sine pulse, 2ms pulse duration. Testing shall consist of one shock in each direction in each axis, for a total of 6 shock inputs.(1 time) 2. Square Wave Shock 30G peak acceleration, 180 inches/sec velocity change. There shall be one shock in each direction in each axis, for a total of 6 shock inputs.(1 time)
7	Altitude Non-operating storage / shipment	0 - 40,000 feet(12,192m)

{ Result Evaluation Criteria }

There should be no change which might affect the practical display function when the display quality test is conducted under normal operating condition.

Product Specification

7. International Standards

7-1. Safety

- a) UL 1950 Third Edition, Underwriters Laboratories, Inc. Jan. 28, 1995.
Standard for Safety of Information Technology Equipment Including Electrical Business Equipment.
- b) CAN/CSA C22.2 No. 950-95 Third Edition, Canadian Standards Association, Jan. 28, 1995.
Standard for Safety of Information Technology Equipment Including Electrical Business Equipment.
- c) EN 60950 : 1992+A1: 1993+A2: 1993+A3: 1995+A4: 1997+A11: 1997
IEC 950 : 1991+A1: 1992+A2: 1993+A3: 1995+A4: 1996
European Committee for Electrotechnical Standardization(CENELEC)
EUROPEAN STANDARD for Safety of Information Technology Equipment Including Electrical
Business Equipment.

7-2. EMC

- a) ANSI C63.4 "Methods of Measurement of Radio-Noise Emissions from Low-Voltage Electrical and Electrical Equipment in the Range of 9kHz to 40GHz." American National Standards Institute(ANSI), 1992
- b) C.I.S.P.R "Limits and Methods of Measurement of Radio Interface Characteristics of Information Technology Equipment." International Special Committee on Radio Interference (Standards apply by CISPR22 class B).
- c) EN 55022 "Limits and Methods of Measurement of Radio Interface Characteristics of Information Technology Equipment." European Committee for Electrotechnical Standardization (CENELEC), 1988

Product Specification

8. Packing

8-1. Designation of Lot Mark

a) Lot Mark

A	B	C	D	E	F	G	H	I	J	K	L	M
---	---	---	---	---	---	---	---	---	---	---	---	---

A,B,C : SIZE
 D : YEAR
 E : MONTH
 F,G : PANEL CODE
 H : ASSEMBLY CODE
 I,J,K,L,M : SERIAL NO.

Note:

1. YEAR

YEAR	97	98	99	2000	2001	2002	2003	2004	2005	2006	2007
Mark	7	8	9	0	1	2	3	4	5	6	7

2. MONTH

MONTH	Jan.	Feb.	Mar.	Apr.	May.	Jun.	Jul.	Aug.	Sep.	Oct.	Nov.	Dec.
Mark	1	2	3	4	5	6	7	8	9	10	11	12

b) Location of Lot Mark

Serial NO. is printed on the label. The label is attached to the backside of the LCD module.
 This is subject to change without prior notice.

8-2. Packing Form

a) Package quantity in one box : 5 pcs

b) Box Size : 530mm × 307mm × 453mm

Product Specification

9. PRECAUTIONS

Please pay attention to the followings when you use this TFT LCD module.

9-1. MOUNTING PRECAUTIONS

- (1) You must mount a module using holes arranged in four corners.
- (2) You should consider the mounting structure so that uneven force(ex. Twisted stress) is not applied to the module.
And the case on which a module is mounted should have sufficient strength so that external force is not transmitted directly to the module.
- (3) Please attach the surface transparent protective plate to the surface in order to protect the polarizer. Transparent protective plate should have sufficient strength in order to resist external force.
- (4) You should adopt radiation structure to satisfy the temperature specification.
- (5) Acetic acid type and chlorine type materials for the cover case are not desirable because the former generates corrosive gas of attacking the polarizer at high temperature and the latter causes circuit break by electro-chemical reaction.
- (6) Do not touch, push or rub the exposed polarizers with glass, tweezers or anything harder than HB pencil lead. And please do not rub with dust clothes with chemical treatment.
Do not touch the surface of polarizer for bare hand or greasy cloth.(Some cosmetics are detrimental to the polarizer.)
- (7) When the surface becomes dusty, please wipe gently with absorbent cotton or other soft materials like chamois soaks with petroleum benzene. Normal-hexane is recommended for cleaning the adhesives used to attach front / rear polarizers. Do not use acetone, toluene and alcohol because they cause chemical damage to the polarizer.
- (8) Wipe off saliva or water drops as soon as possible. Their long time contact with polarizer causes deformations and color fading.
- (9) Do not open the case because inside circuits do not have sufficient strength.

9-2. OPERATING PRECAUTIONS

- (1) The spike noise causes the mis-operation of circuits. It should be lower than following voltage :
 $V = \pm 200\text{mV}$ (Over and under shoot voltage)
- (2) Response time depends on the temperature.(In lower temperature, it becomes longer.)
- (3) Brightness depends on the temperature. (In lower temperature, it becomes lower.)
And in lower temperature, response time(required time that brightness is stable after turned on) becomes longer.
- (4) Be careful for condensation at sudden temperature change. Condensation makes damage to polarizer or electrical contacted parts. And after fading condensation, smear or spot will occur.
- (5) When fixed patterns are displayed for a long time, remnant image is likely to occur.
- (6) Module has high frequency circuits. Sufficient suppression to the electromagnetic interference shall be done by system manufacturers. Grounding and shielding methods may be important to minimized the interference.

Product Specification

9-3. ELECTROSTATIC DISCHARGE CONTROL

Since a module is composed of electronic circuits, it is not strong to electrostatic discharge. Make certain that treatment persons are connected to ground through wrist band etc. And don't touch interface pin directly.

9-4. PRECAUTIONS FOR STRONG LIGHT EXPOSURE

Strong light exposure causes degradation of polarizer and color filter.

9-5. STORAGE

When storing modules as spares for a long time, the following precautions are necessary.

- (1) Store them in a dark place. Do not expose the module to sunlight or fluorescent light. Keep the temperature between 5°C and 35°C at normal humidity.
- (2) The polarizer surface should not come in contact with any other object.
It is recommended that they be stored in the container in which they were shipped.

9-6. HANDLING PRECAUTIONS FOR PROTECTION FILM

- (1) When the protection film is peeled off, static electricity is generated between the film and polarizer. This should be peeled off slowly and carefully by people who are electrically grounded and with well ion-blown equipment or in such a condition, etc.
- (2) The protection film is attached to the polarizer with a small amount of glue. If some stress is applied to rub the protection film against the polarizer during the time you peel off the film, the glue is apt to remain on the polarizer.
Please carefully peel off the protection film without rubbing it against the polarizer.
- (3) When the module with protection film attached is stored for a long time, sometimes there remains a very small amount of glue still on the polarizer after the protection film is peeled off.
- (4) You can remove the glue easily. When the glue remains on the polarizer surface or its vestige is recognized, please wipe them off with absorbent cotton waste or other soft material like chamois soaked with normal-hexane.