

**LC151X01-A3
15.1" XGA TFT LCD**

**PRELIMINARY
SPECIFICATION**

LG.Philips LCD: Rev. 0.0, MAY 23, 2001

1. GENERAL DESCRIPTION

The LC151X01-A3 is a Color Active Matrix Liquid Crystal Display with an integral Cold Cathode Fluorescent Lamp (CCFL) backlight system. The matrix employs a-Si Thin Film Transistor as the active element. It is a transmissive type display operating in the normally white mode. This TFT-LCD has a 15.1 inches diagonally measured active display area with XGA resolution (768 vertical by 1024 horizontal pixel array). Each pixel is divided into Red, Green and Blue sub-pixels or dots which are arranged in vertical stripes. Gray scale or the brightness of the sub-pixel color is determined with a 8-bit gray scale signal for each dot, thus, presenting a palette of 16,777,216 colors.

The LC151X01-A3 has been designed to apply the TMDS interface method. The LC151X01-A3 LCD is intended to support displays where high brightness, wide viewing angle, high color saturation, and high color depth are very important.

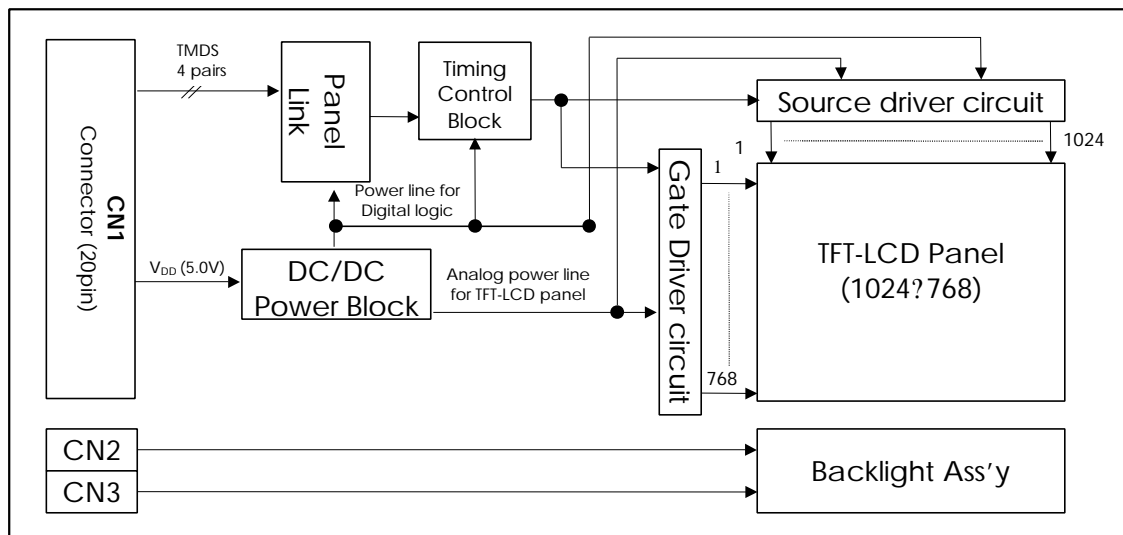

General Features

Active screen	15.1 inches (cm) diagonal
Outline dimensions	352.0 (H) × 263.5 (V) × 18.0 (D) mm (typ.)
Pixel pitch	0.300 mm × 0.300 mm
Pixel format	1024 horiz. By 768 vert. pixels
	RGB stripe arrangement
Color depth	8bit (16,777,216 Colors)
Luminance, White	400 cd/m ² (typ)
Power Consumption	Total 22.0 Watt @ full black (typ.)
Weight	1800g (typ.)
Display operating mode	Transmissive mode, normally white
Surface treatments	Hard coating (3H), Anti-glare treatment of the front polarizer

2. ABSOLUTE MAXIMUM RATINGS

The following are maximum values which, if exceeded, may cause faulty operation or damage to the unit.

Table 1 ABSOLUTE MAXIMUM RATINGS

Parameter	Symbol	Values		Units	Notes
		Min.	Max.		
Power Input Voltage	V_{CC}	-0.5	5.8	Vdc	at $25 \pm 5^\circ\text{C}$
Operating Temperature	T_{OP}	0	50	$^\circ\text{C}$	1
Storage Temperature	T_{ST}	-20	60	$^\circ\text{C}$	1
Operating Ambient Humidity	H_{OP}	10	90	%RH	1
Storage Humidity	H_{ST}	10	90	%RH	1

Note 1: Temperature and relative humidity range are shown in the figure below. Wet bulb temperature should be 39° Max, and no condensation of water.

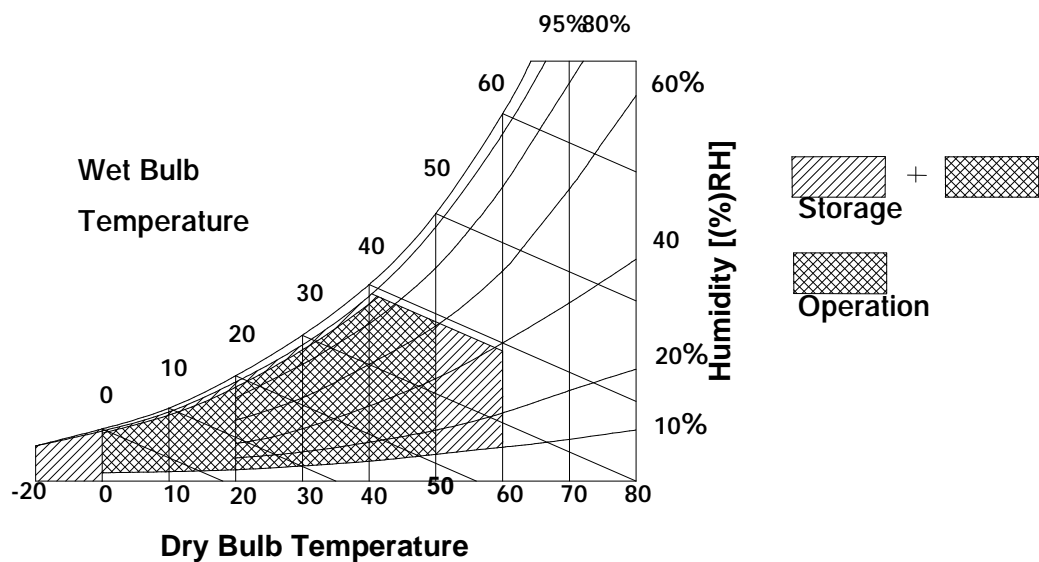

3. ELECTRICAL SPECIFICATIONS

3.1 Electrical Characteristics

The LC151X01-A3 requires two power inputs. One is employed to power the LCD electronics and to drive the TFT array and liquid crystal. The second input which powers the CCFL, is typically generated by an inverter. The inverter is an external unit to the LCD.

Table 2 ELECTRICAL CHARACTERISTICS:

Parameter	Symbol	Values			Units	Notes
		Min.	Typ.	Max.		
MODULE:						
Power Supply Input Voltage	V_{CC}	4.5	5.0	5.5	Vdc	
Power Supply Input Current	I_{CC}	-	1.0	-	A	1
Differential Impedance	Z_m	-	100	-	ohm	2
Power Consumption	P_c	-	5.0	-	Watts	1
Rush current	I_{RUSH}	-	2.2	-	A	3
LAMP						
Operating Voltage	V_{BL}	520(9mA)	540(8 mA)	660(3mA)	V_{RMS}	4
Operating Current	I_{BL}	3.0	8.0	9.0	mA	
Established Starting Voltage						5
at 25°C		-	-	900	V_{RMS}	
at 0°C		-	-	1170	V_{RMS}	
Operating Frequency	f_{BL}	35	50	80	kHz	
Discharge Stabilization Time	T_s			3	Minutes	6
Power Consumption(4 CCFL's)	P_{BL}	-	17.2	18.92	Watts	7
Half Life Time		50,000	-	-	Hrs	8

Note 1: The specified current and power consumption are under the $V_{CC} = 5.0V$, 25°C, $f_v = 60Hz$ condition whereas full black pattern is displayed and f_v is the frame frequency.

Note 2: This impedance value is needed to proper display and measured form TMDS Tx to the mating connector.

Note 3: The duration of rush current is about 1ms.

Note 4: The variance of the voltage is $\pm 10\%$.

Note 5: The transformer output voltage in the inverter must be high, considering loss of the ballast capacitor in the inverter.

Note 6: Let's define the brightness of the lamp after being lighted for 5 minutes as 100%. T_s is the time required for the brightness of the center of the lamp to be not less than 95%.

Note 7: The lamp power consumption shown above does not include loss of external inverter.

Note 8: The life time is determined as the time at which brightness of lamp is 50% compared to that of initial value at the typical lamp current on condition of continuous operating at $25 \pm 2^\circ C$. **The design of the inverter must have specifications for the lamp in LCD Assembly.** The performance of the Lamp in LCM, for example life time or brightness, is extremely influenced by the characteristics of the DC-AC Inverter.

So all the parameters of an inverter should be carefully designed so as not to produce too much leakage current from high-voltage output of the inverter.

When you design or order the inverter, please make sure unwanted lighting caused by the mismatch of the lamp and the inverter (no lighting, flicker, etc) never occurs. When you confirm it, the LCD assembly should be operated in the same condition as installed in your instrument.

3.2 Interface Connections

This LCM has three interface connections, a 20 pin connector is used for the module electronics and, two four pin connectors are used for the integral back light system.

The interface pin configuration for the connector is shown in the table below.

LCD Connector: DF19KR-20P-1H (Hirose) or GT100-20P-LS-SMT-R (LG Cable)

Mating Connector: DF19G-20S-1C (Hirose cable type) or DF19G-20S-1F (Hirose FPC type)

Table 3 MODULE CONNECTOR PIN CONFIGURATION(CN1)

Pin	Symbol	I/O	Description
1	GND	INPUT	Ground
2	RxC-	INPUT	TMDS Clock signal (-)
3	RxC+	INPUT	TMDS Clock signal (+)
4	GND	INPUT	Ground
5	Rx0-	INPUT	Minus Blue TMDS Signal (-)
6	Rx0+	INPUT	Plus Blue TMDS Signal (+)
7	GND	INPUT	Ground
8	Rx1-	INPUT	Minus Green TMDS Signal (-)
9	Rx1+	INPUT	Plus Green TMDS Signal (+)
10	NC	NC	NC
11	Rx2-	INPUT	Minus Red TMDS Signal (-)
12	Rx2+	INPUT	Plus Red TMDS Signal (+)
13	NC	NC	NC
14	GND	INPUT	Ground
15	GND	INPUT	Ground
16	GND	INPUT	Ground
17	VCC	INPUT	Power Supply 5.0V (typical)
18	VCC	INPUT	Power Supply 5.0V (typical)
19	VCC	INPUT	Power Supply 5.0V (typical)
20	GND	INPUT	Ground

Note 1: All GND (ground) pins should be connected together and also be connected to the LCD's metal frame.

Note 2: All VCC (power input) pins should be connected together.

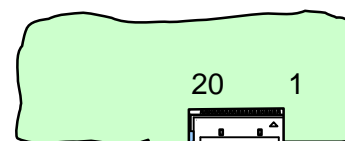

The backlight interface connector is a model BHR-04VS-1, manufactured by JST. The mating connector part number is SM02(8.0)B-BHS-1-TB or equivalent. The pin configuration for the connector is shown in the table below.

Table 4 BACKLIGHT CONNECTOR PIN CONFIGURATION (CN2,CN3)

Pin	Symbol	Description	Notes
1	HV	Lamp power input(High)	
2	HV	Lamp power input(High)	
3	NC	No connect	
4	LV	Lamp power input(Low)	

Note 1: The input power terminal (High) is colored pink.

3.3 Signal Timing Specifications

This is the signal timing required at the input of the TMD5 Transmitter. All of the interface signal timing should be satisfied with the following specifications for its proper operation.

Table 5 Timing Table

ITEM	SYMBOL	MIN.	TYP.	MAX.	UNIT	NOTE
Dclk	Period	t_{CLK}	15.4	15.4	15.4	ns 65MHz
Hsync	Period	t_{HP}	1064	1344	1392	t_{CLK}
	Width-Active	t_{WH}	8	136	-	
Vsync	Period	t_{VP}	774	806	840	t_{HP}
	Frequency	f_V	-	60	-	Hz
	Width-Active	t_{WV}	2	6	-	t_{HP}
DE (Data Enable)	Horizontal Back Porch	t_{HBP}	16	160	-	t_{CLK}
	Horizontal Front Porch	t_{HFP}	16	24	-	
	Vertical Back Porch	t_{VBP}	2	29	-	t_{HP}
	Vertical Front Porch	t_{VFP}	2	3	-	

Note 1: Hsync Period and Hsync Width-Active should be even number times of t_{CLK} . If the value is odd number times of t_{CLK} , display control signal can be asynchronous.

3.4 Signal Timing Waveforms

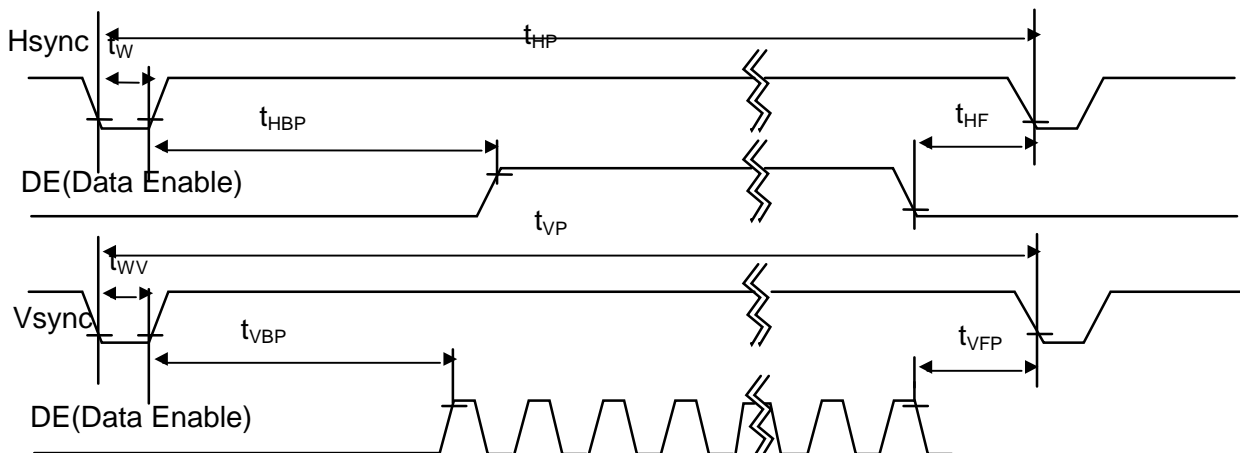
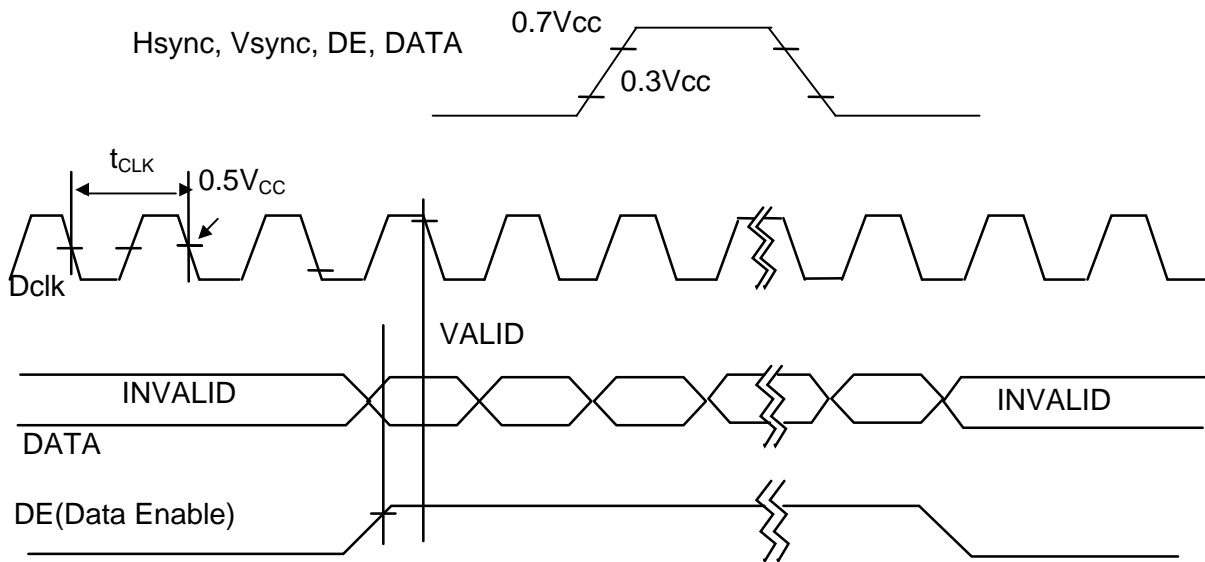

3.5 Color Input Data Reference

The brightness of each primary color (red, green and blue) is based on the 8-bit gray scale data input for the color; the higher the binary input, the brighter the color. The table below provides a reference for color versus data input.

Table 7 COLOR DATA REFERENCE

Color		Input Color Data																							
		Red								Green								Blue							
		MSB				LSB				MSB				LSB				MSB				LSB			
		R7	R6	R5	R4	R3	R2	R1	R0	G7	G6	G5	G4	G3	G2	G1	G0	B7	B6	B5	B4	B3	B2	B1	B0
Basic Colors	Black	0	0	0	0	0	0	0	0	0	0	0	0	0	0	0	0	0	0	0	0	0	0	0	0
	Red(255)	1	1	1	1	1	1	1	1	0	0	0	0	0	0	0	0	0	0	0	0	0	0	0	0
	Green(255)	0	0	0	0	0	0	0	0	1	1	1	1	1	1	1	1	0	0	0	0	0	0	0	0
	Blue(255)	0	0	0	0	0	0	0	0	0	0	0	0	0	0	0	0	1	1	1	1	1	1	1	1
	Cyan	0	0	0	0	0	0	0	0	1	1	1	1	1	1	1	1	1	1	1	1	1	1	1	1
	Magenta	1	1	1	1	1	1	1	1	0	0	0	0	0	0	0	0	1	1	1	1	1	1	1	1
	Yellow	1	1	1	1	1	1	1	1	1	1	1	1	1	1	1	1	0	0	0	0	0	0	0	0
	White	1	1	1	1	1	1	1	1	1	1	1	1	1	1	1	1	1	1	1	1	1	1	1	1
Red	Red(000) Dark	0	0	0	0	0	0	0	0	0	0	0	0	0	0	0	0	0	0	0	0	0	0	0	
	Red(001)	0	0	0	0	0	0	0	1	0	0	0	0	0	0	0	0	0	0	0	0	0	0	0	
	Red(002)	0	0	0	0	0	0	1	0	0	0	0	0	0	0	0	0	0	0	0	0	0	0	0	
	:	:	:	:	:	:	:	:	:	:	:	:	:	:	:	:	:	:	:	:	:	:	:	:	
	Red(253)	1	1	1	1	1	1	0	1	0	0	0	0	0	0	0	0	0	0	0	0	0	0	0	
	Red(254)	1	1	1	1	1	1	1	0	0	0	0	0	0	0	0	0	0	0	0	0	0	0	0	
	Red(255) Bright	1	1	1	1	1	1	1	1	0	0	0	0	0	0	0	0	0	0	0	0	0	0	0	
Green	Green(000) Dark	0	0	0	0	0	0	0	0	0	0	0	0	0	0	0	0	0	0	0	0	0	0	0	
	Green(001)	0	0	0	0	0	0	0	0	0	0	0	0	0	0	1	0	0	0	0	0	0	0	0	
	Green(002)	0	0	0	0	0	0	0	0	0	0	0	0	0	1	0	0	0	0	0	0	0	0	0	
	:	:	:	:	:	:	:	:	:	:	:	:	:	:	:	:	:	:	:	:	:	:	:	:	
	Green(253)	0	0	0	0	0	0	0	0	1	1	1	1	1	1	0	1	0	0	0	0	0	0	0	
	Green(254)	0	0	0	0	0	0	0	0	1	1	1	1	1	1	1	0	0	0	0	0	0	0	0	
	Green(255) Bright	0	0	0	0	0	0	0	0	1	1	1	1	1	1	1	0	0	0	0	0	0	0	0	
Blue	Blue(000) Dark	0	0	0	0	0	0	0	0	0	0	0	0	0	0	0	0	0	0	0	0	0	0	0	
	Blue(001)	0	0	0	0	0	0	0	0	0	0	0	0	0	0	0	0	0	0	0	0	0	0	1	
	Blue(002)	0	0	0	0	0	0	0	0	0	0	0	0	0	0	0	0	0	0	0	0	0	1	0	
	:	:	:	:	:	:	:	:	:	:	:	:	:	:	:	:	:	:	:	:	:	:	:	:	
	Blue(253)	0	0	0	0	0	0	0	0	0	0	0	0	0	0	0	1	1	1	1	1	1	1	0	
	Blue(254)	0	0	0	0	0	0	0	0	0	0	0	0	0	0	0	1	1	1	1	1	1	1	0	
	Blue(255) Bright	0	0	0	0	0	0	0	0	0	0	0	0	0	0	0	1	1	1	1	1	1	1	1	

3.6 Power Sequence

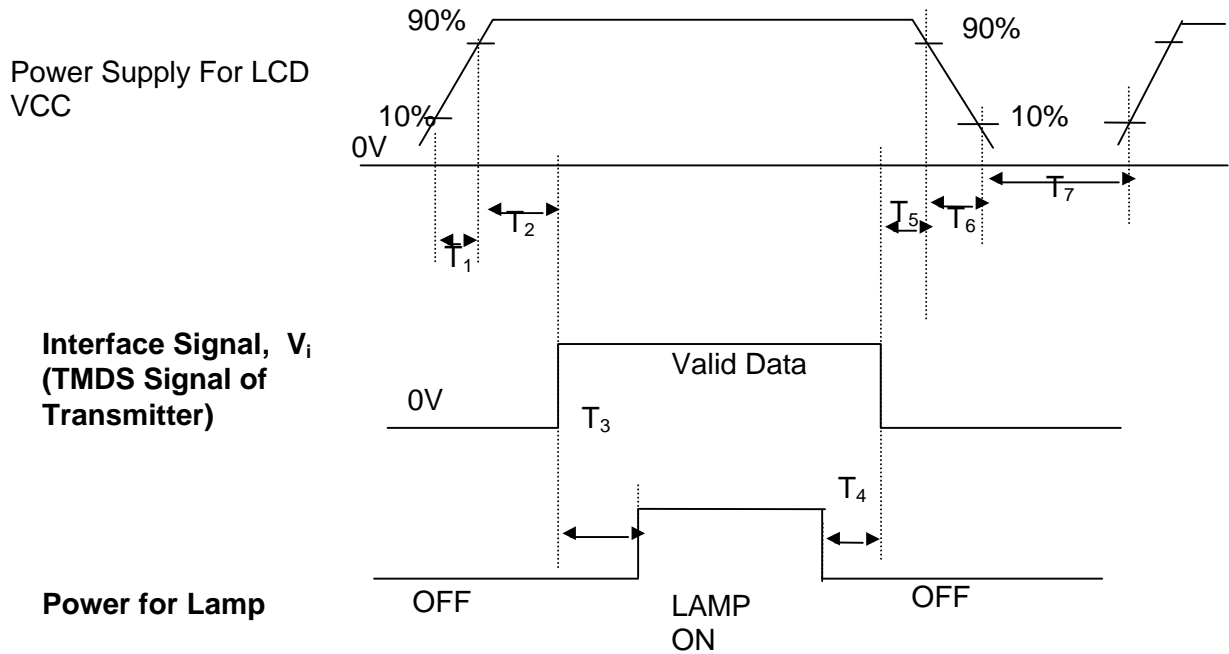

Parameter	Values			Units
	Min.	Typ.	Max.	
T_1	-	-	10	ms
T_2	0	-	50	ms
T_3	200	-	-	ms
T_4	200	-	-	ms
T_5	0	-	50	ms
T_6	-	-	10	ms
T_7	400	-	-	ms

- Note1: Please avoid floating state of interface signal at invalid period.
- Note2: When the interface signal is invalid, be sure to pull down the power supply for LCD VCC to 0V.
- Note3: Lamp power must be turn on after power supply for LCD and interface signal are valid.

4. OPTICAL SPECIFICATIONS

Optical characteristics are determined after the unit has been 'ON' and stable for approximately 30 minutes in a dark environment at 25°C. The values specified are at an approximate distance 50cm from the LCD surface at a viewing angle of and ? equal to 0?. FIG. 1 presents additional information concerning the measurement equipment and method.

FIG. 1 Optical Characteristic Measurement Equipment and Method

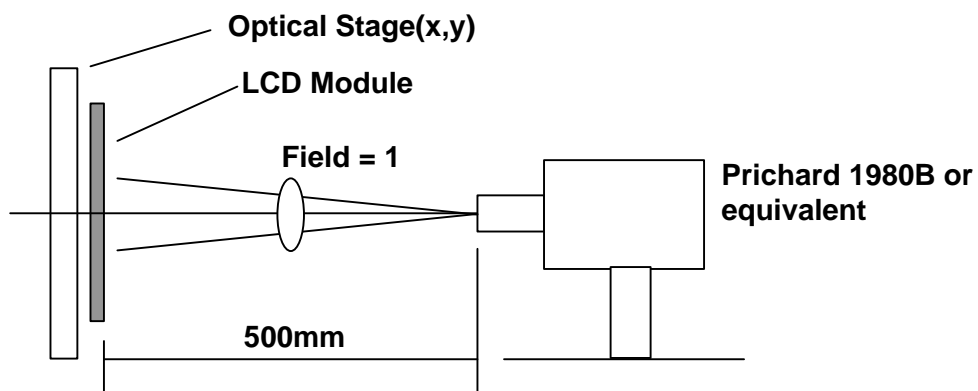

Table 8 OPTICAL CHARACTERISTICS

(Ta=25°, Vcc=3.3V, f_V =60Hz, Dclk=65MHz, I_{BL}=8mA)

Parameter	Symbol	Values			Units	Notes
		Min.	Typ.	Max.		
Contrast Ratio	CR	300	350	-		1
Surface Luminance, white	L _{WH}	350	400	-	cd/m ²	2
Luminance Variation	dWHITE	-	-	30		3
Response Time	Tr				ms	4
Rise Time	Tr _R	-	7.0	10		
Decay Time	Tr _D	-	18.0	20		
CIE Color Coordinates						
Red	X _R	0.607	0.637	0.667		
	Y _R	0.310	0.340	0.370		
Green	X _G	0.260	0.290	0.320		
	Y _G	0.576	0.606	0.636		
Blue	X _B	0.112	0.142	0.172		
	Y _B	0.059	0.089	0.119		
White	X _W	0.283	0.313	0.343		
	Y _W	0.299	0.329	0.359		
Viewing Angle					degree	
x axis, right (F=0°)	r	55	60	-		5
x axis, left (F=180°)	l	55	60	-		
y axis, up (F=90°)	u	40	45	-		
y axis, down (F=270°)	d	40	45	-		
Gray Scale	d	-	-	-		6

Note 1: Contrast Ratio (CR) is defined mathematically as:

$$\frac{\text{(Surface Luminance with all white pixels)}}{\text{(Surface Luminance with all black pixels)}}$$

Contrast ratio shall be measured at the center of the display (Location 1).
For more information see FIG. 2.

Note 2: The Luminance is luminance value at 5 points average across the LCD surface 50cm from the surface with full white screen (Location 1,2,3,4,5).
For more information see FIG.2.

Note 3: The variation in surface luminance, SB_V is defined as :

$$\frac{\text{Maximum (} B_1, B_2, \dots B_{13} \text{) - Minimum (} B_1, B_2, \dots B_{13} \text{)}}{\text{Average (} B_1, B_2, \dots B_5 \text{)}} \quad ? \quad 100(\%)$$

Where B1 to B13 are the luminance with all pixels displaying white at 13 locations.

FIG. 2 Luminance

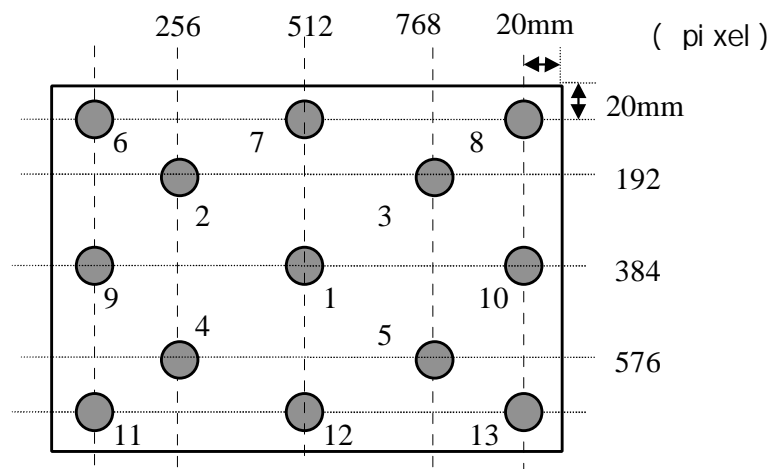

Note 4: The response time is defined as the following figure and shall be measured by switching the input signal for “black” and “white”.

FIG. 3 Response Time

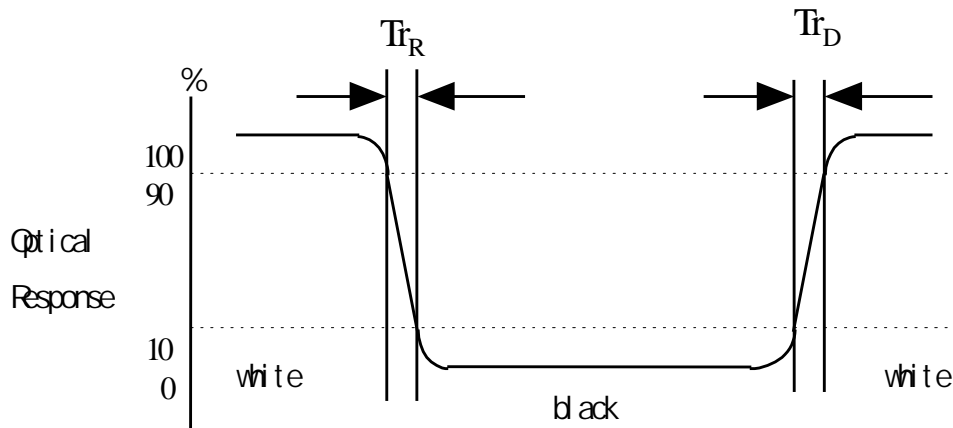

Note 5: Viewing angle is the angle at which the contrast ratio is greater than 10. The angles are determined for the horizontal or x axis and the vertical or y axis with respect to the z axis which is normal to the LCD surface.

FIG. 4 Definition of Viewing angle range

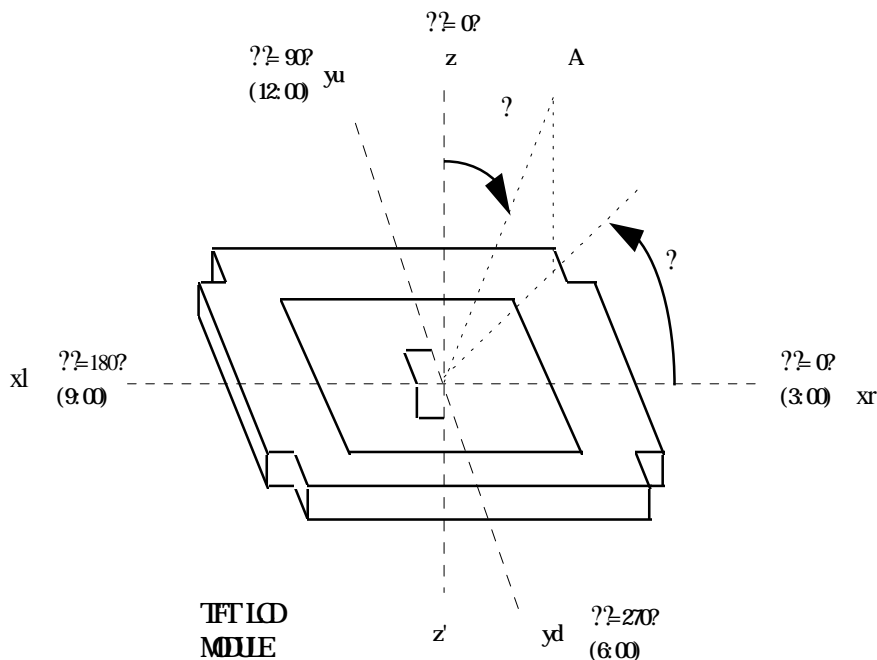

Note 6: Gray scale specification.

No.	Gray	Relative Brightness (%)		
		Min.	Typ.	Max.
1	000	-	0.2	1.0
2	015	-	0.4	1.5
3	031	-	0.6	2.0
4	047	0.1	1.2	3.0
5	063	0.5	2.5	4.5
6	079	1.5	4.1	6.6
7	095	2.2	5.8	9.5
8	111	4.0	8.2	13.0
9	127	6.5	11.5	17.0
10	143	10.5	16.5	23.0
11	159	17.0	23.4	30.0
12	175	24.0	32.3	40.0
13	191	35.0	42.9	51.0
14	207	47.5	54.8	65.0
15	223	64.0	74.4	85.0
16	239	87.0	94.9	99.0
17	255	100	100	100

5. MECHANICAL CHARACTERISTICS

The contents provide general mechanical characteristics for the model LM150X1. In addition, the figures in the next page are detailed mechanical drawings of the LCD.

Outside dimensions:

Horizontal	352.0 ± 0.5 mm
Vertical	263.5 ± 0.5 mm
Depth	18.0 + 0.5 mm

Bezel area:

Horizontal	311.2 ± 0.5 mm
Vertical	234.4 ± 0.5 mm

Active Display area:

Horizontal	307.2 mm
Vertical	230.4 mm

Weight (approximate) : 1800g (typ), 1950 g (max)

Surface Treatment: Hard coating 3H
Anti-glare treatment of the front polarizer.

< FRONT VIEW >

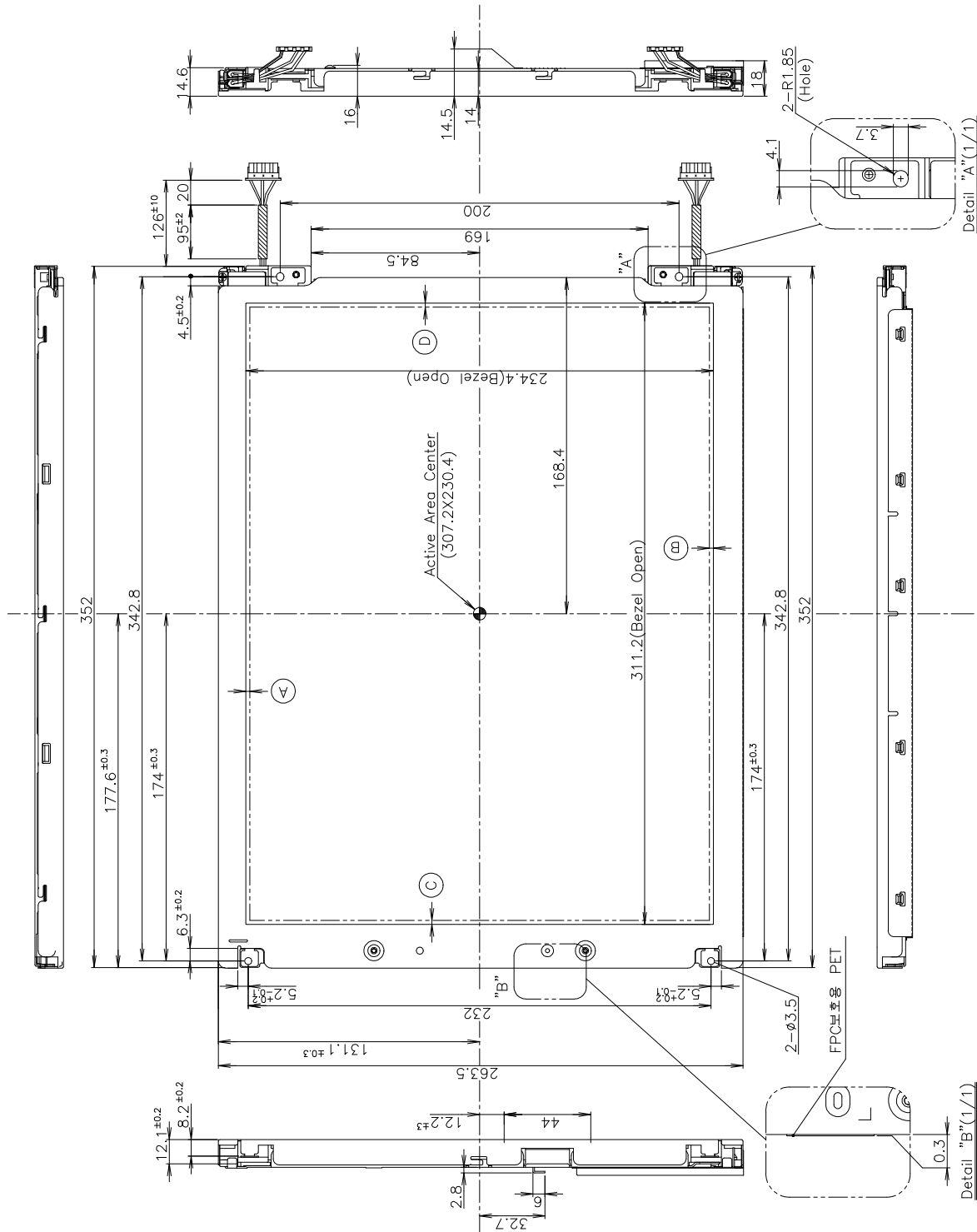

NOTES

1. Unspecified tolerances to be ± 0.5
2. This drawing is only preliminary data and can be changed without previous notice
3. Gap between Top case and Glass is $0.2(+0.5/-0.2)$
4. Tilt and partial disposition tolerance of display area are as follow
 - 1) Y-Direction : $|A-B| \leq 1.0$
 - 2) X-Direction : $|C-D| \leq 1.0$

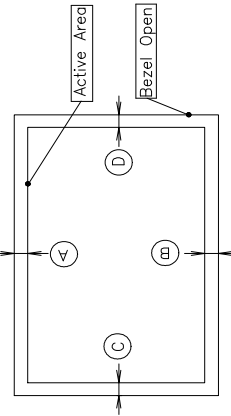

5. The same shape is same demension.

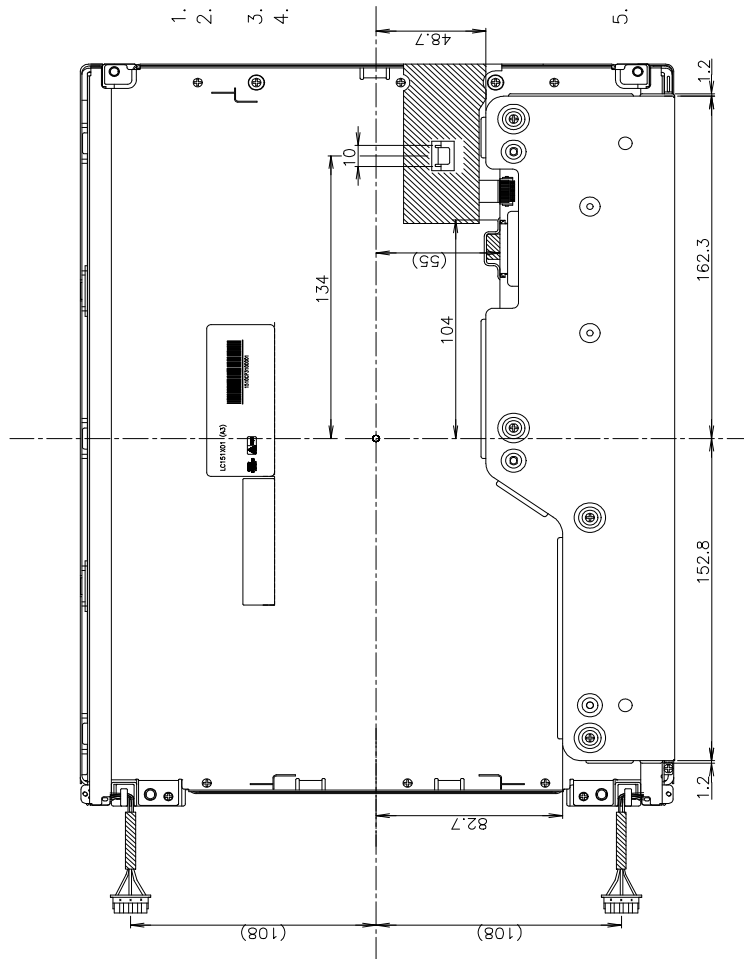

< REAR VIEW >

6. RELIABILITY

Environment test condition

No.	Test Item	Conditions
1	High temperature storage test	Ta = 60°C 240h
2	Low temperature storage test	Ta = -20°C 240h
3	High temperature operation test	Ta = 50°C 50%RH 240h
4	Low temperature operation test	Ta = 0°C 240h
5	Vibration test (non-operating)	Wave form: random Vibration level: 1.0G RMS Bandwidth: 10-500 Hz Duration: X,Y,Z, 20 min One time each direction
6	Shock test (non-operating)	Shock level: 120G Waveform: half sine wave, 2ms Direction: ±X, ±Y, ±Z One time each direction
7	Altitude operating storage/shipment	0 - 10,000 feet (3.048 m) 0 - 40,000 feet (12.192 m)

{Result Evaluation Criteria}

There should be no change which might affect the practical display function when the display quality test is conducted under normal operating condition.

7. INTERNATIONAL STANDARDS

7.1 Safety

- a) UL 1950 Third Edition, Underwriters Laboratories, Inc. Jan. 28, 1995. Standard for Safety of Information Technology Equipment Including Electrical Business Equipment.
- b) CAN/CSA C22.2 No. 950-95 Third Edition, Canadian Standards Association, Jan. 28, 1995. Standard for Safety of Information Technology Equipment Including Electrical Business Equipment.
- c) EN 60950 : 1992 + A1 : 1993 + A2 : 1993 + A3 : 1995 + A4 : 1997 + A11 : 1997 IEC 950 : 1991 + A1 : 1992 + A2 : 1993 + A3 : 1995 + A4 : 1996 European Committee for Electrotechnical Standardization (CENELEC) EUROPEAN STANDARD for Safety of Information Technology Equipment Including Electrical Business Equipment.

7.2 EMC

- a) ANSI C63.4 "Methods of Measurement of Radio-Noise Emissions from Low-Voltage Electrical and Electronic Equipment in the Range of 9kHz to 40GHz." American National Standards Institute(ANSI), 1992.
- b) C.I.S.P.R "Limits and Methods of Measurement of Radio Interference Characteristics of Information Technology Equipment." International Special Committee on Radio Interference
- c) EN 55022 "Limits and Methods of Measurement of Radio Interference Characteristics of Information Technology Equipment." European Committee for Electrotechnical Standardization (CENELEC),1988

8. PACKING

8.1 Designation of Lot Mark

a) Lot Mark

A	B	C	D	E	F	G	H	I	J	K	L	M
---	---	---	---	---	---	---	---	---	---	---	---	---

A, B, C: Inch CODE
 D: YEAR
 E: MONTH
 F,G: Panel Code
 H: Assembly Code
 I, J, K, L,M: SERIAL NO.

Note 1: YEAR (D)

YEAR	98	99	2000	2001	2002	2003	2004	2005	2006	2007	2008
Mark	8	9	0	1	2	3	4	5	6	7	8

Note 2: MONTH (E)

MONT H	Jan.	Feb.	Mar.	Apr.	May	Jun.	Jun.	Aug	Sep	Oct.	Nov	Dec

Mark	1	2	3	4	5	6	7	8	9	A	B	C

b) Location of Lot Mark

Serial No. Is printed on the label. The label is attached to the backside of the LCD module. This is subject to change without prior notice.

8.2 Packing Form

a) Package quantity in one box: 8pcs

b) Box Size: 344 mm x 315 mm x 426 mm.

9. MOUNTING PRECAUTIONS

- You must mount a module using holes arranged in four corners or four sides.
- You should consider the mounting structure so that uneven force (ex. twisted stress) is not applied to the module. And the case on which a module is mounted should have sufficient strength so that external force is not transmitted directly to the module.
- Please attach a transparent protective plate to the surface in order to protect the polarizer. Transparent protective plate should have sufficient strength in order to resist external force.
- You should adopt radiation structure to satisfy the temperature specification.
- Acetic acid type and chlorine type materials for the cover case are not desirable because the former generates corrosive gas of attacking the polarizer at high temperature and the latter causes circuit break by electro-chemical reaction.
- Do not touch, push or rub the exposed polarizers with glass, tweezers or anything harder than HB pencil lead. Please do not rub with dust clothes with chemical treatment. Do not touch the surface of polarizer for bare hand or greasy cloth. (Some cosmetics are detrimental to the polarizer.)
- When the surface becomes dusty, please wipe gently with absorbent cotton or other soft materials like chamois soaked with petroleum benzene. Normal-hexane is recommended for cleaning the adhesives used to attach front / rear polarizers. Do not use acetone, toluen and alcohol because they cause chemical damage to the polarizer.
- Wipe off saliva or water drops as soon as possible. Their long time contact with polarizer causes deformations and color fading.
- Do not open the case because inside circuits do not have sufficient strength.

9.1 OPERATING PRECAUTIONS

- The spike noise causes the mis-operation of circuits. It should be lower than following voltage: $V = ? 200\text{mV}$ (Over and under shoot voltage).
- Response time depends on the temperature (in lower temperature, it becomes longer) .
- Brightness depends on the temperature (in lower temperature, it becomes lower). In lower temperature, response time (required time that brightness is stable after turned on) becomes longer.
- Be careful for condensation at sudden temperature change. Condensation makes damage to polarizer or electrical contacted parts. And after fading condensation, smear or spot will occur.
- When fixed patterns are displayed for a long time, remnant image is likely to occur.

- A module has high frequency circuit. If you need to shield the electromagnetic noise, please do in yours. When a Back-light unit is operating, it sounds. If you need to shield the noise, please do in yours.

9.2 ELECTROSTATIC DISCHARGE CONTROL

Since a module is composed of electronic circuits, it is not strong to electrostatic discharge. Make certain that treatment persons are connected to ground through wrist band etc . And don't touch interface pin directly.

9.3 PRECAUTIONS FOR STRONG LIGHT EXPOSURE

Strong light exposure causes degradation of polarizer and color filter.

9.4 STORAGE

- When storing modules as spares for a long time, the following precautions are necessary.
- Store them in a dark place. Do not expose the module to sunlight or fluorescent light. Keep the temperature between 5° and 35° at normal humidity.
- The polarizer surface should not come in contact with any other object. It is recommended that they be stored in the container in which they were shipped.

9.5 HANDLING PRECAUTIONS FOR PROTECTION FILM

- When the protection film is peeled off, static electricity is generated between the film and polarizer. This should be peeled off slowly and carefully by people who are electrically grounded and with well ion- blown equipment or in such a condition, etc.
- The protection film is attached to the polarizer with a small amount of glue. If some stress is applied to rub the protection film against the polarizer during the time you peel off the film, the glue is apt to remain on the polarizer. Please carefully peel off the protection film without rubbing it against the polarizer.
- When the module with protection film attached is stored for a long time, sometimes there remains a very small amount of glue still on the polarizer after the protection film is peeled off.
- You can remove the glue easily. When the glue remains on the polarizer surface or its vestige is recognized, please wipe them off with absorbent cotton waste or other soft material like chamois soaked with normal-hexane.