

Serious RTTY contesting and the SO2R concept in 2007

Kari Hirvonen, OH2BP

Pre word

Here at the higher latitudes, we all know this very well. Under Miss Aurora's umbrella and quite far away from the QSO Bowl in the South, reaching a top level rank in any global contest is a very hard job. The only way to pursue success is in general to improve the technology Contest Site technology and to further develop operating skills. As we all know well, this is a never ending, life time long challenge for a Serious Contester.

Quite a many North Europeans have a lot of space to establish antenna tower farm and if there is motivation, enough time and some money, for sure it's a good base to start a better Life. Today's Contest Site is fully packed with networked PC's, several radios and linears, automatic and rapid band switching, intelligent antenna & filter select and a stacking option by a single key touch for the whole system. In case you're a good SO1R operator and look for a significant improvement, you should seriously consider to take a further step forward to SO2R in order to maximize your contest score.

Equipment, all automatic

This report shows one example how to set up a serious Contesting Station using full size SO2R. This OH2BP is designed to serve mainly the RTTY mode, however all ideas and presented technology works fine for CW and SSB, too. My modest two aluminum towers with rotators @18m & @24m are placed in the background of a house in rural area. The QTH is located near the Helsinki-Vantaa Airport.

The Station equipped with A- and B-radios, two networked PC's, two automatic tune MosFET Linears, several flat screen displays, antenna swapper/stacker relay box and control logic unit. Automatic band change works fast, eq. by a single key touch both radios QSYs to selected band and the QRG. The logic take care of selecting right antenna(s) and needed filters and/or stubs on the signal route. See Drawing 1, RTTY SO2R Concept.

SO2R Control Logic

In early hours of the second day in a 48h contest, the operator is typically quite lazy to continuously sweep the bands for S&P and archive the marginal QSOs. These contacts however, as we all know, might be very valuable in final score board.

The band change in general has to be very easy to manage, (maybe the old time tape label Plate and Load settings on Tube Linears are now phasing out). In an older set up you had to make manual antenna switching and PA retune maybe hundred times in a long contest.

With any autoLinear you don't have to raise your butt from your comfortable chair to do these time consuming adjustments thus you're eager to do that much more often and S&P rare QSOs into the winning log. Yeah!

One of the major extra functions of the SO2R Control Logic is to prevent human errors. Quite often we select a wrong antenna or Band Pass filter and only after few minutes we recognize the reason for discontinued QSO stream or even damaged radio.

My most harmful experience was, when my SO2R logic was under development, and use of two radios on the same QRG at full power cost a large penny in

destroyed front-end of the receiver. A proper SO2R logic removed this problem.

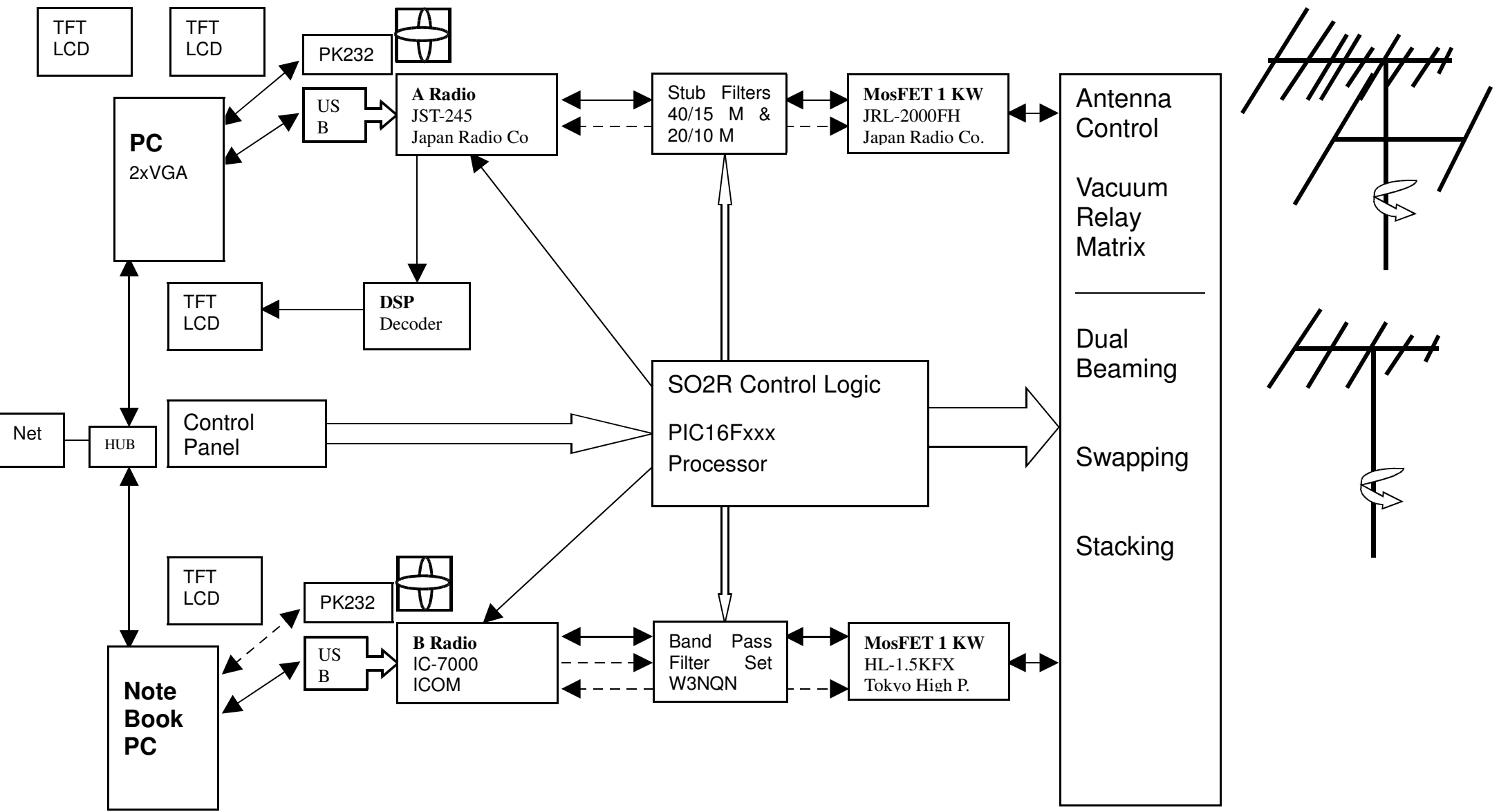

OH2BP SO2R 2007 CONCEPT / Cushcraft X9 9 el & XM240 + Fritzel 5 el + sloopers

Antenna Swapping & Stacking

At my station I have a homebrew 25 military vacuum relay box for all antenna and filter remote control. This relay matrix makes it possible to swap the two antenna directions in a second.

Let us say that you have the big beam to JA and the multiplier yagi to EU. While having a good run to JA-direction, you can switch the beams to collect weakest calling EU station or vice versa. Some heavy contesters might appreciate the 'QRG cleaner' option which helps you to hold the QRG with the other antenna. Today this dual beam direction feature is part of all well equipped contest sites. See Figure 1, The Antenna Swapper Box.

In case you turn both yagis to the same direction, all antennas can be stacked beaming into the same direction. In my vacuum relay matrix there is a 50 Ohm / 25 Ohm Ferrite Balun the operator may select to match two 50 Ohm antennas to same radio. See Drawing 2, Principle of Stacking

We all know how a serious Contester highly appreciates this few dB gain archived by the antenna stack to one direction. Stacking might help you to be the first or the only one to get a very rare DX multiplier.



Figure 1. The Antenna Swapper Box.

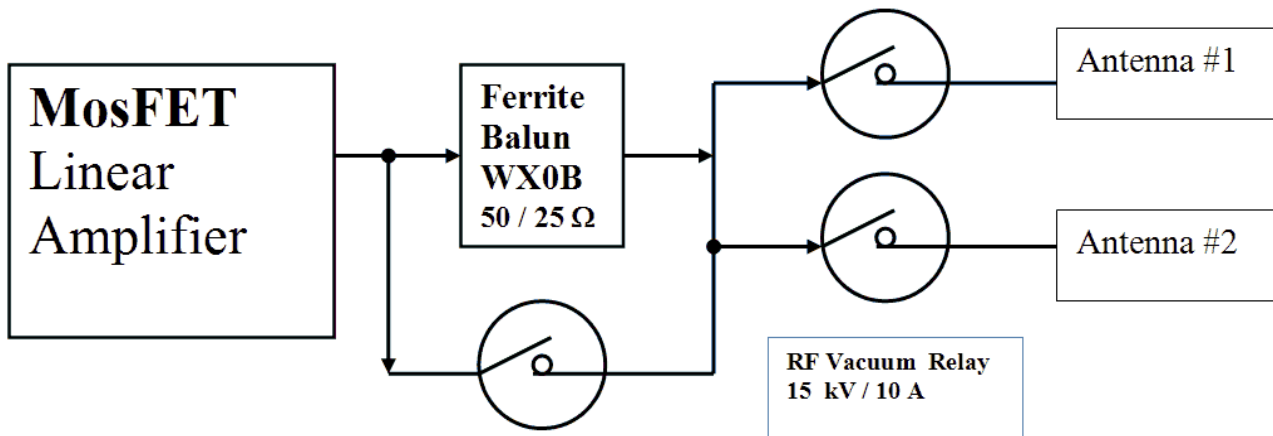

Drawing 2. Principle of stacking.

SO2R strategy

Here in Northern Europe we quite seldom are able to enjoy long lasting, huge pile-ups. In order to shoot everything that is QRV in the Contest we're doing the "Search & Pounce" continuously, sweeping out and vacuuming QSOs out of all bands.

You'd better also be aware of the stochastic and non-predictable band openings, like short bursts on 10m. The continuous scanning of the bands is my point.

If your SO2R site supports fast and automatic line tune for entire set of radios, linears and filters, it's a great tool for Search and Pounce.

The above concept of benefiting two separate radios simultaneously gives a great opportunity to work number of multipliers. You just ask the rare multi to QSY to other radio's QRG on other band, which you already know is open. On the TX message buffer memories you should have the sked QRG's ready for that kind of QSY requests.

Additional hints for RTTY

USB adapter

In the most demanding working conditions with high power PA's, interference problems might be an issue. Today it's not recommended to connect any audio, FSK and PTT signal directly to the PC audio card or COM port. At least a fully galvanic isolation in the signal path is a must. All this can create big mess of cables.

I prefer using a USB digi mode adapter, like RigExpert®, a small cigarette box on the rear of the exciter and just a single USB cable to your PC. The above also includes a full function audio card built in and the CAT port for the remote rig control. Just hook a single wire up to your Laptop and you're on the way. This is cool for a DXpedition, too.

Dual Decoder

Just like using several radios for contesting, the serious RTTY operator would need at least two different receive data decoders. This is because of detected distortion on the signal via multi/polar path or simultaneous LP/SP propagation or in case the calling station has an offset from your QRG etc.

In addition, the operator might wish to have one wide bandwidth filter/decoder (in my case old faithful PK-232's) and narrow rig filter (250/500 Hz, maybe in

cascade) or the DSP (Digital Signal Processing). The best decoder prints the weak station callsign to one of the screens for operator to pick up. It's varying time to time which one decodes less carbage.

Today, I am glad to tell that a number of new radios already have a built-in RTTY decoder feature (at least ICOM756PRO and IC7000 does). I am using today both rigs and different decoders are working in parallel at my site.

RTTY scope

An old tradition is to visualize the RTTY signal by an oscilloscope. In case you have the above mentioned PK232, KAM or any similar TNC you'll get easily the X- and Y- signals to a dual beam scope.

Right tuned RTTY signal creates the cross ellipse pattern on scope screen. In the hassle of contest you are able to quick search and retune both radios for a new stations. By this easy and fast method you will miss less received information and can pick up all stations

calling on edge or stations with drifting QRG drifting.

Listening RTTY during the contest

It's hard to believe, but one of the most important skills for a RTTY operator is hearing. All sent and received information is text on screen, however, efficient contest operation is based on hearing, too. By hearing you know the RX/TX status of the entire SO2R set up. So you are aware of the RX and TX phase of the radios and when it's time to focus looking at the screens. By means of this you know the right time slot to transmit with either radio and when to take a look at the screen. All other free time between is for S&P on the B-radio !

My secret is using standard stereo wireless headphones having A-radio audio on the right ear and the B-radio on left. The operator listens simultaneously both radios RX and TX audio with the rig Monitor ON. Wireless function gives you also freedom to move in the shack for any other important reason - like to take a beer from the fridge in the Ham Shack. See Drawing 3, Listening RTTY SO2R



Wireless Stereo Phone Set 800 Mhz (€40) *) Keep the Transmit Monitor On

Hearing the RTTY SO2R

Drawing 3. Hearing the RTTY.

Multi display use

Drawing 1, RTTY SO2R Concept shows several flat screen panels in the shack. Here is an example of my configuration:

Radio A – screen 1: dynamic contest software (waterfall)

Radio A –screen 2: band map, score window, cluster etc.

Radio B – screen 1: dynamic contest software (waterfall)

Radio B – screen 2: enlarged IC-7000 rig display

Extra screen 1: additional DSP Decoder for Radio A

Extra screen 2: the contest log page, DX Cluster, real time Propagation & Gray line map, statistics and other valuable information.

Feel free to try the best layout and configuration that suits for your preferences and working habits.

Remember to post your useful hints to post-contest 3830 and Skype your friends to share the your experience!

Score improvement

After using years my modest SO2R set-up I estimate that some 10-20 % more QSOs can be logged compared to manual SO1R. It means that you have trained the skills to run and fully benefit the SO2R.

In some contest you are not allowed to more than on signal at any time on air to prevent full use of SO2R. No problems, in the logic of SO2R there is a function to prevent two TX to transmit at same time.

An good RTTY operator achieves in good conditions typically a 50 QSO/h rate with a single TX. During best periods at my SO2R site the QSO/h meter has occasionally jumped up to 120-130 QSO/h in a huge pile-up. This means ca. 80+QSO/h rate during the best hour period here in high latitudes. Every time during the peak hours the operator's adrenaline will increase in a very pleasant way. The Contest IS!

Who will be the very first CCF member to break the 2k total SOAB QSO barrier in any coming RTTY contest ?

See you on digital modes !

73s de
Kari OH2BP



“Mr. OH-RTTY”: 200 contests with several Top Ten positions, 100k RTTY QSOs.